

Kodak T Plate Processors and Stackers

Technical Specifications

	T 860 Plate Processor	T 1250 Plate Processor	
Processor type	Thermal processor rated up to 15,000 sqm/year		
Processing sections	Developing, washing, gumming, drying		
Accredited digital plates	Kodak Electra XD Thermal Plates, Kodak Electra Excel HRL / HRO Thermal Plates, Kodak Sword Ultra Thermal Plates		
Maximum plate width	860 mm	1250 mm	
Minimum plate length	300 mm		
Maximum plate length	1350 mm		
Gauge range	0.15 - 0.30 mm		
Developer temperature range	18°C- 35°C		
Developer tank volume	37 liters	54 liters	
Water supply	1 - 6 bar (15 - 87 psi)		
Processing speed	0.45 - 2.58 m/min, dwell time 10 - 55 seconds		
Electrical power	200-208 / 220 / 230-240 VAC, single-phase, 50/60 Hz 24 A (max)		
Power outlet	Included for stacker		
Standard accessories	Input and output tables, drip trays, conductivity probe, built-in chiller, built-in wash water recirculation		
Width x length x height (crated)	150 x 194 x 139 cm	187 x 194 x 139 cm	
Entrance / exit height	Adjustable: 860 - 940 mm		
Weight (uncrated)	450 kg	500 kg	
Weight (crated)	684 kg	780 kg	
Approvals	Complies with CE, UL/cUL and RoHS, C-TICK		
	Kodak 860 Compact Plate Stacker	Kodak 860 Plate Stacker	Kodak 1250 Plate Stacker
Maximum plate width	860 mm	860 mm	1250 mm
Minimum plate width	200 mm	200 mm	200 mm
Maximum plate length	770 mm	1200 mm	1450 mm
Minimum plate length	300 mm	300 mm	300 mm
Maximum capacity	100 plates (0.3 mm)	80 plates (0.3 mm)	80 plates (0.3 mm)
Entrance height	Adjustable: 860 - 1100 mm	Adjustable: 860 - 940 mm	Adjustable: 860 - 940 mm
Speed	0.7-6 m/min at 220 V	0.7-6 m/min at 220 V	0.7-6 m/min at 220 V
Width x length x height (crated)	123 cm x 117 cm x 157 cm	140 cm x 112 cm x 115 cm	160 cm x 160 cm x 105 cm
Weight (uncrated)	80 kg	82.5 kg	105 kg
Weight (crated)	130 kg	135 kg	182 kg
Electrical power	200 -240 VAC, 1A, 50/60 Hz		



Kodak
T Plate Processors

Dimensions

T 860 Plate Processor

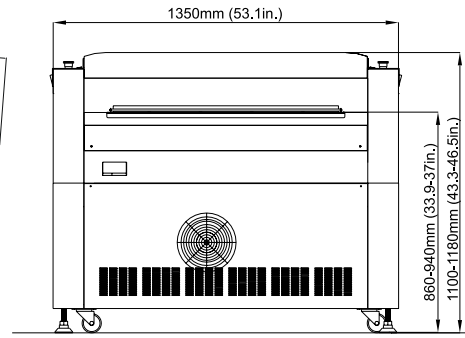
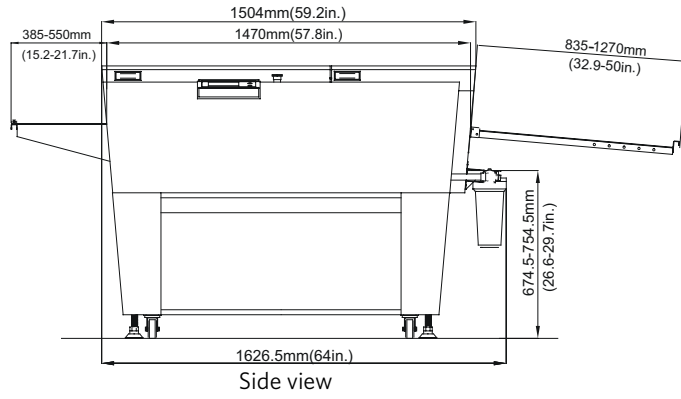

Front view

860 Compact Plate Stacker

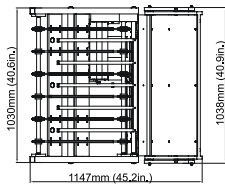
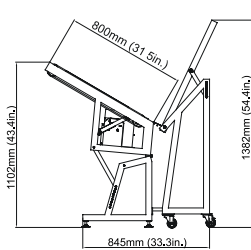

Max. height

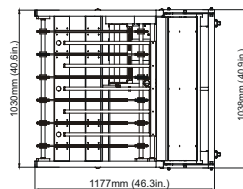
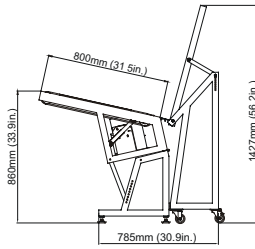

Min. height

860 Plate Stacker

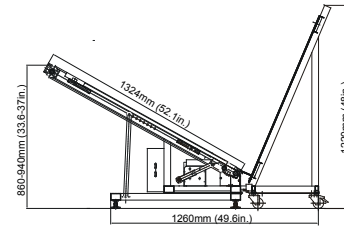

Side view

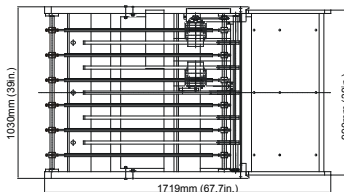

Top view

T 1250 Plate Processor

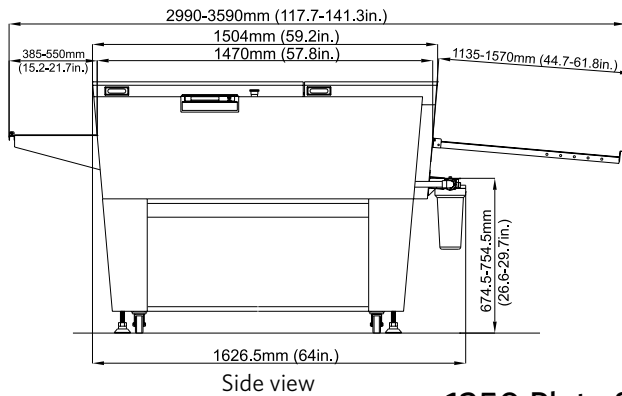

Side view

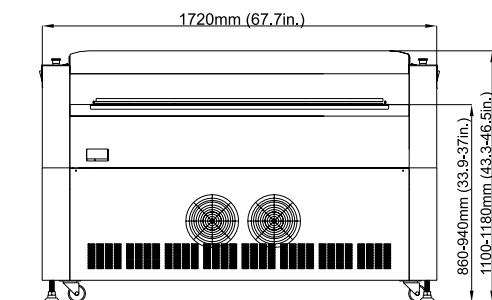

Front view

1250 Plate Stacker

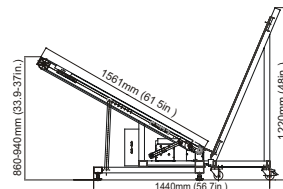

Side view

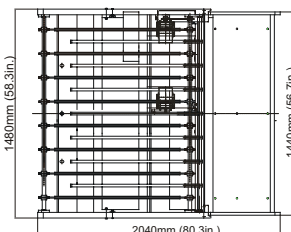

Top view

To learn more about solutions from Kodak:
Visit graphics.kodak.com

Produced using Kodak Technology.

Eastman Kodak Company
343 State Street
Rochester, NY 14650 USA

©Kodak, 2009. Kodak, Electra Excel and Sword Ultra are trademarks of Kodak.

Subject to technical change without notice.

W.PC.034.0409.en.05